

BIBUS



Diffusers

 **JÄGER**
Umwelt-Technik

Disc diffusers

HD 200 series	4-5
HD 270 series	6-7
HD 340 series	8-9

Tube diffusers

TD 65-2 series	10-11
TD 65-2 G series	12-13
TD 90-2 series	14-15
TD 90-2 G series	16-17
TD 63 G series	18-19

Accessoires**20-25****Applications****Aeration**

Water treatment and environmental technology
Waste water treatment plants
Ponds and fish tanks
Aeration of tanks containing chemical and biological liquids

Aqua-air and design pillars

Advantages

- Different membrane material available
- Low installation costs
- Non-standard slots are provided on request
- Low Maintenance

HD 200 DISC DIFFUSER

Dimensions

Diameter total [A] / effective	Installation height above pipe [B]	Overall height [C]	Orifice	Thread
233/184 mm	30 mm	60 mm	6 mm	R 3/4"



Installation drawing

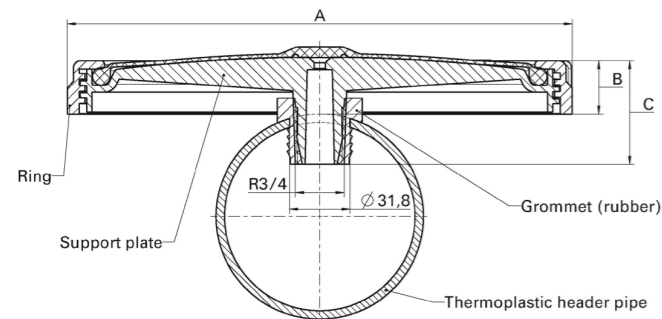

A = 233 mm
B = 30 mm
C = 60 mm

SSOTE and headloss for HD 200 F053A

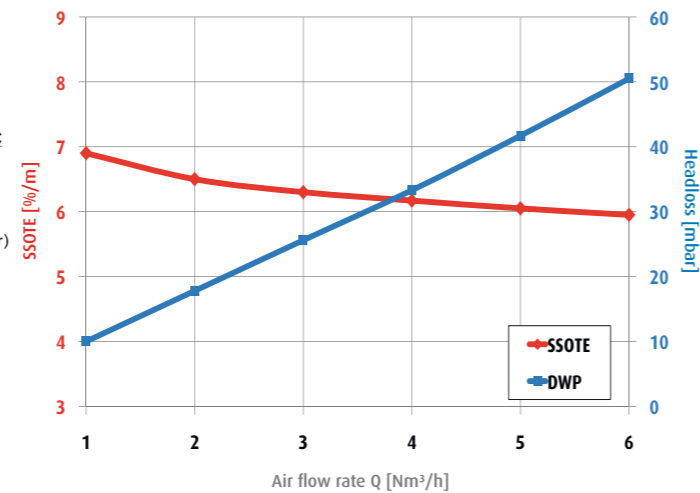

Perforated area	Air flow rate at standard operating conditions	Max. overload / maintenance air flow rate	Operating mode
0.025 m ²	1 - 6 Nm ³ / h	8 Nm ³ / h	continuous / intermittent

Connectors to plastic header pipe

	Colour	Permitted wall thickness of header tube	Diameter of straight-drilled hole	Material
Rubber saddle	black	4 - 8 mm	32 +0/-0,5 mm	EPDM 75 ± 5 Shore A
PVC saddle 90 + 110 mm	grey/white	2 mm	36 ± 0,5 mm	Soft PVC
Clamp adapter 90 + 110 + 114,3 mm	black	2 mm	multiple	PP 20 % GF / SI / VA

HD 200 DISC DIFFUSER

Membrane materials

Material	Techn. standard	EPDM F053A	EPDM F057A	Techn. standard	Silicone
Colour		black	black		green
Plasticiser (%)		28	9		0
Density (g/cm ³)	DIN EN ISO 1183-1	1.07	1.06	DIN EN ISO 1183-1	1.17
Tensile strength (N/mm ²)	DIN 53504	>10	>8	DIN 53504	>9
Elongation at break (%)	DIN 53504	>450	>300	DIN 53504	>510
Tear strength (N/mm)	DIN EN ISO 34-1 (method A)	>6	>3	DIN EN ISO 34-1 (method B)	>36
Hardness (Shore A)	DIN ISO 7619	52 ± 5	60 ± 5	DIN 53505	60 ± 5
Operating air temperature (°C)		5 - 80	5 - 80		5 - 100
Operating water temperature (°C)		5 - 40	5 - 40		5 - 40

Support plates

Material	Colour
PP 30% GF	black

Accessories

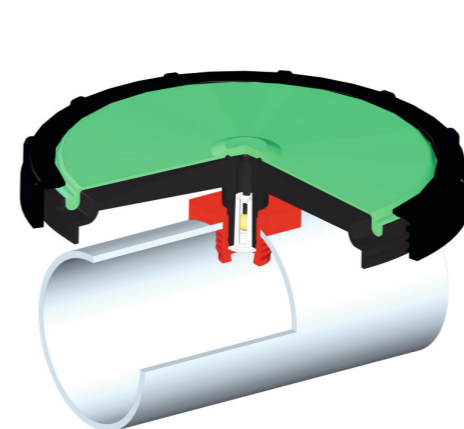

Rubber saddle PVC saddle Check valve



Clamp adapter with female thread Clamp adapter without thread

HD 270 DISC DIFFUSER

Dimensions

Diameter total/effective [A]	Overall height embrane top of tube [B]	Total height [C]	Orifice	Thread
268/218 mm	30 mm	60 mm	8 mm	R 3/4"



Installation drawing

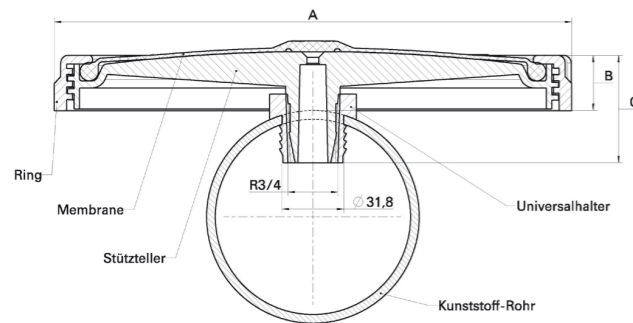

A = 268 mm
B = 30 mm
C = 60 mm

SSOTE and headloss for HD 270 F053

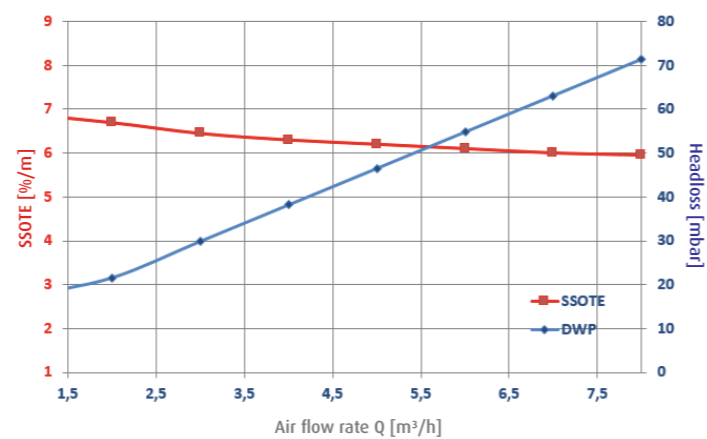

Perforated area	Air flow rate at standard operating conditions	Max. overload / maintenance air flow rate	Operating mode
0,037 m²	1,5 - 8 Nm³/h	10 Nm³/h	continuous / intermittent

Connectors to plastic header pipe

	Colour	Permitted wall thickness of header tube	Diameter of straight-drill hole	Material
Rubber saddle	black	4 - 8 mm	32 +0/-0,5 mm	EPDM 75 ± 5 Shore A
PVC saddle 90 + 110 mm	grey/white	2 mm	36 ± 0,5 mm	Soft PVC
Clamp adapter 90 + 110 + 114,3 mm	black	2 mm	diverse	PP 20 % GF / SI / VA

HD 270 DISC DIFFUSER

Membrane materials

Material	Techn. standard	EPDM F053A	EPDM F057A	Techn. standard	Silicone
Colour		black	black		green
Plasticiser (%)		28	9		0
Density (g/cm³)	DIN EN ISO 1183-1	1,07	1,06	DIN EN ISO 1183-1	1,17
Tensile strength (N/mm²)	DIN 53504	>10	>8	DIN 53504	>10
Elongation at break (%)	DIN 53504	>450	>300	DIN 53504	>610
Tear strength (N/mm)	DIN EN ISO 34-1 (Methode A)	>6	>3	ASTM D624B	>51
Hardness (Shore A)	DIN ISO 7619	52 ± 5	60 ± 5	DIN 53505	60 ± 5
Operating temperature air (°C)		5 - 80	5 - 80		5 - 100
Operating temperature water (°C)		5 - 40	5 - 40		5 - 40

Other materials

Material	Colour
PP 30% GF	black

Accessories



Rubber saddles

PVC saddles

Check valve

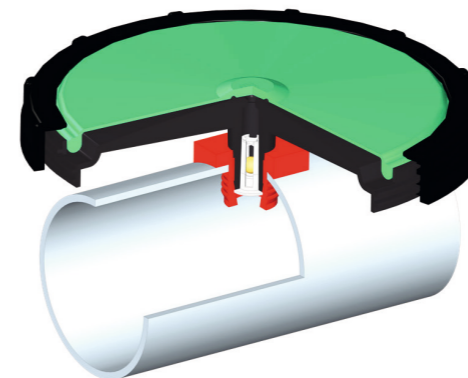

HD 340 DISC DIFFUSER

Dimensions

Diameter total/effective [A]	Overall height embrane top of tube [B]	Total height [C]	Orifice	Thread
346/295 mm	46 mm	76 mm	10 mm	R 3/4" +1"



Installation drawing

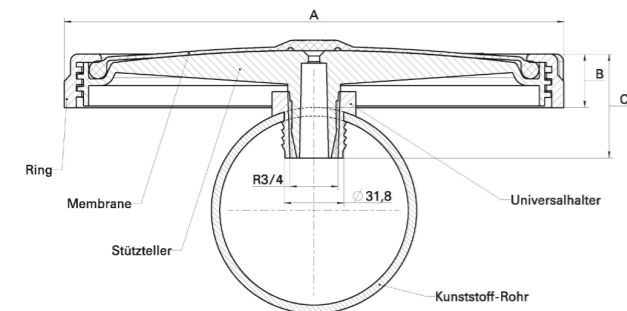

A = 346 mm
B = 46 mm
C = 76 mm

SSOTE and headloss for HD 340 F053

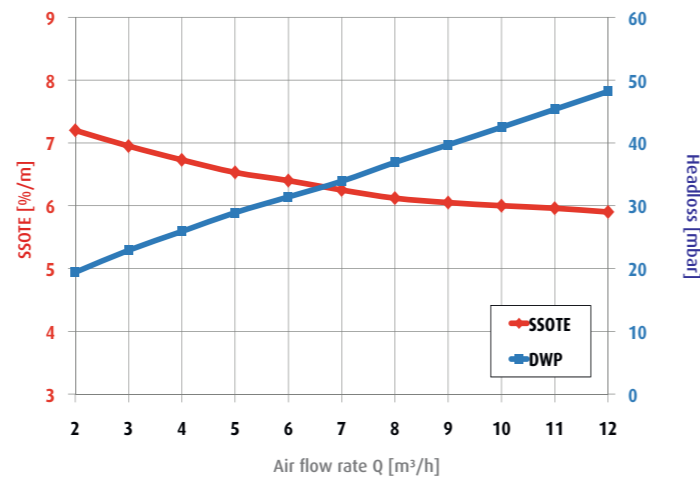

Perforated area	Air flow rate at standard operating conditions	Max. overload / maintenance air flow rate	Operating mode
0,060 m ²	2 - 12 Nm ³ /h	15 Nm ³ /h	continuous / intermittent

Connectors to plastic header pipe

	Colour	Permitted wall thickness of header tube	Diameter of straight-drill hole	Material
Rubber saddle	black	4 - 8 mm	32 +0/-0,5 mm	EPDM 75 ± 5 Shore A
PVC saddle 90 + 110 mm	grey/white	2 mm	36 ± 0,5 mm	Hard PVC
Clamp adapter 90+110+114,3mm	black	2 mm	multiple	PP 20 % GF / SI / VA

HD 340 DISC DIFFUSER

Membrane materials

Material	Techn. standard	EPDM F053A	EPDM F057A	Techn. standard	Silicone
Colour		black	black		green
Plasticiser (%)		28	9		0
Density (g/cm ³)	DIN EN ISO 1183-1	1,07	1,06	DIN EN ISO 1183-1	1,17
Tensile strength (N/mm ²)	DIN 53504	>10	>8	DIN 53504	>10
Elongation at break (%)	DIN 53504	>450	>300	DIN 53504	>610
Tear strength (N/mm)	DIN EN ISO 34-1 (Methode A)	>6	>3	ASTM D624B	>51
Hardness (Shore A)	DIN ISO 7619	52 ± 5	60 ± 5	DIN 53505	60 ± 5
Operating temperature air (°C)		5 - 80	5 - 80		5 - 100
Operating temperature water (°C)		5 - 40	5 - 40		5 - 40

Support plates

Material	Colour
PP 30% GF	black

Accessories



Rubber saddles PVC saddles Check valve



Clamp adapters with internal thread Clamp adapters without thread

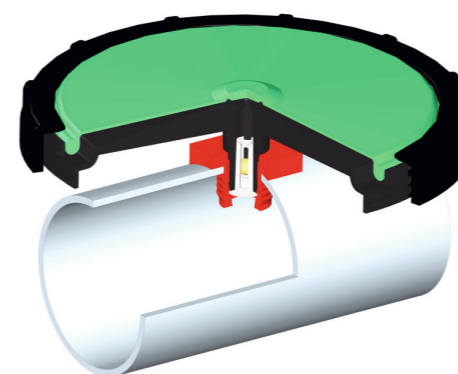

TD 65-2 TUBE DIFFUSER

Dimensions

Material	Tube diameter (grooved)	ID-Sleeve	Wall thickness
EPDM	63 mm	~ 65 mm	1,9 ± 0,15 mm
Silikon	63 mm	~ 65 mm	1,5 ± 0,15 mm
PUR	63 mm	~ 65 mm	0,6 ± 0,1 mm

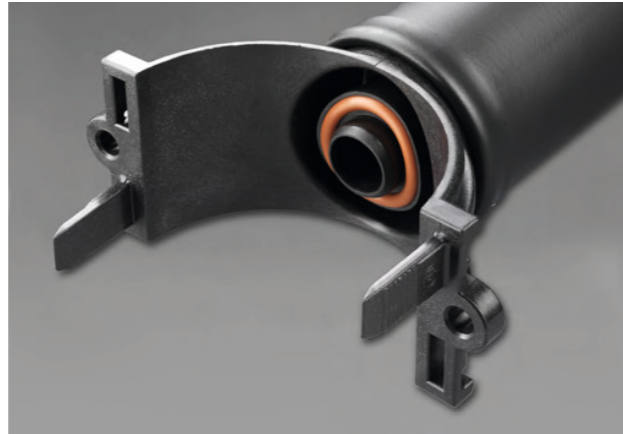

Installation drawing

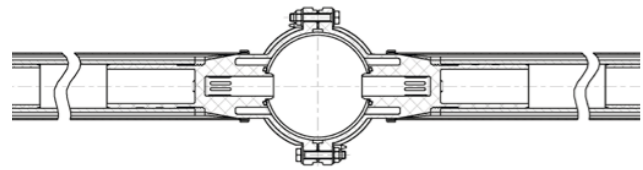

SSOTE and headloss for EPDM 1000 mm

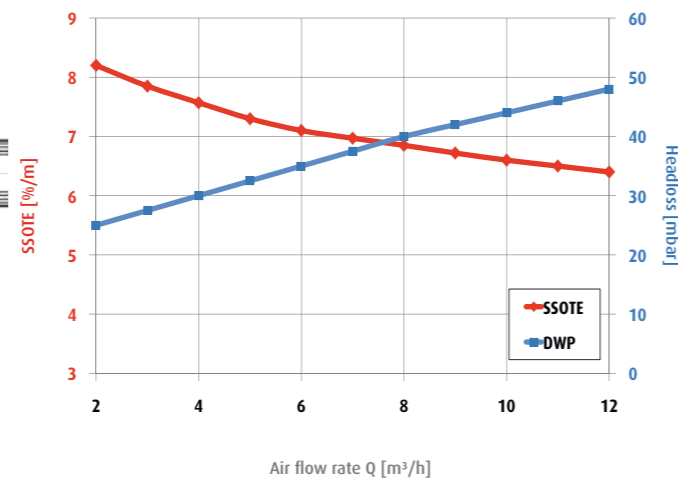

Perforation length	Total length	Perforated area		Air flow rate at standard operating conditions	Max overload/maintenance air flow rate	Operating mode
		EPDM + PU	SI			
1000 mm	1175 mm	0,18 m²	0,16 m²	2 - 12 Nm³/h	20 Nm³/h	continuous / intermittent
750 mm	925 mm	0,135 m²	0,12 m²	1,5 - 9 Nm³/h	15 Nm³/h	continuous / intermittent
500 mm	675 mm	0,09 m²	0,08 m²	1 - 6 Nm³/h	10 Nm³/h	continuous / intermittent

Dimensions for connection to round tubes

Outer diameter	Material	Nominal diameter	Drilling diameter
114,3 mm	SS	100	27 +1/-0 mm
110 mm	PVC	100	27 +1/-0 mm
90 mm	PVC	80	27 +1/-0 mm

TD 65-2 TUBE DIFFUSER

Membrane materials

Material	Norm	EPDMperformace Plus	PUR	Norm	Silikon
Colour		black	green		translucent
Plasticiser (%)		35	0		0
Density (g/cm³)	DIN EN ISO 1183-1	1,11	1,15	DIN EN ISO 1183-1	1,16
Tensile strength (N/mm²)	DIN 53504	>8,5	>35	DIN 53504	>9
Elongation at break (%)	DIN 53504	>550	>500	DIN 53504	>900
Tear strength (N/mm)	DIN EN ISO 34-1	>10	>55	ASTM D 624 B	>38
Hardness (Shore A)	DIN ISO 7619-1	43 ± 5	87 ± 5	DIN 53505	60 ± 5
Operating temperature air (°C)		5 - 80	5 - 80		5 - 100
Operating temperature water (°C)		5 - 40	5 - 40		5 - 40

Other materials

Supporting body	Stainless steel clamp	Screw connection
PP / PP 20% GF	1.4301	1.4301

Accessories



Floor bracket and end plug Half shell without Thread

TD 65-2 G TUBE DIFFUSER

Dimensions

Material	Tube diameter	ID-Sleeve	Wall thickness
EPDM	63 mm	~ 65 mm	1,9 ± 0,15 mm
Silikon	63 mm	~ 65 mm	1,5 ± 0,15 mm
PUR	63 mm	~ 65 mm	0,6 ± 0,1 mm



Installation drawing

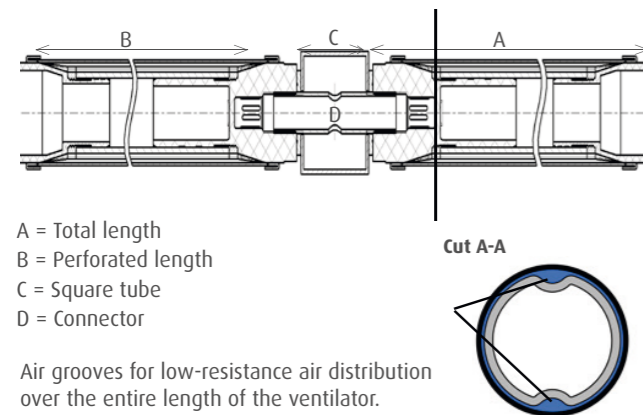

SSOTE and headloss for EPDM 1000 mm

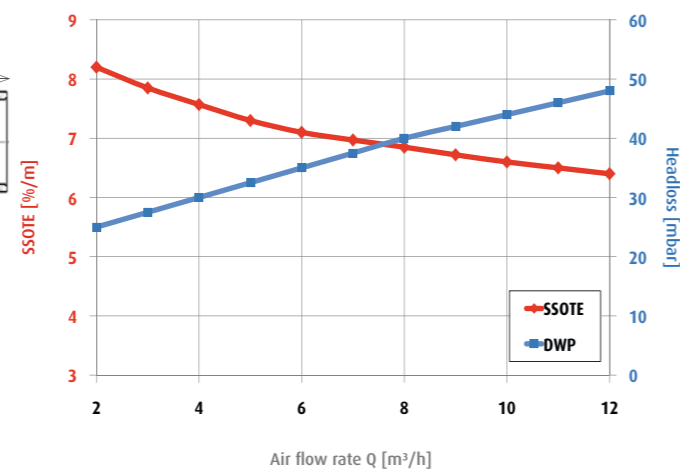

Perforation length [B]	Total length [A]	Perforated area		Air flow rate at standard operating conditions	Max overload/maintenance air flow rate	Operating mode
		EPDM+PU	SI			
1000 mm	1062,5 mm	0,18 m²	0,16 m²	2 - 12 Nm³/h	20 Nm³/h	continuous / intermittent
750 mm	812,5 mm	0,135 m²	0,12 m²	1,5 - 9 Nm³/h	15 Nm³/h	continuous / intermittent
500 mm	562,5 mm	0,09 m²	0,08 m²	1 - 6 Nm³/h	10 Nm³/h	continuous / intermittent

Dimensions for connection to square pipes

Connector [D]	Length for square tube 80 x 80 mm [C]	Length for square tube 100 x 100 mm [C]	Drill hole for connector
Pipe thread ISO 228 - G 1A	145 mm	165 mm	35 +1/-0 mm
Pipe thread ISO 228 - G 3/4A	145 mm	165 mm	28 +1/-0 mm

TD 65-2 G TUBE DIFFUSER

Membrane materials

Material	Techn. standard	EPDMperformance Plus	PUR	Techn. standard	Silicone
Colour		black	green		translucent
Plasticiser (%)		35	0		0
Density (g/cm³)	DIN EN ISO 1183-1	1,11	1,15	DIN EN ISO 1183-1	1,16
Tensile strength (N/mm²)	DIN 53504	>8,5	>35	DIN 53504	>9
Elongation at break (%)	DIN 53504	>550	>500	DIN 53504	>900
Tear strength (N/mm)	DIN EN ISO 34-1	>10	>55	ASTM D 624 B	>38
Hardness (Shore A)	DIN ISO 7619-1	43 ± 5	87 ± 5	DIN 53505	60 ± 5
Operating temperature air (°C)		5 - 80	5 - 80		5 - 100
Operating temperature water (°C)		5 - 40	5 - 40		5 - 40

Other materials

Supporting body	Stainless steel clamp
PP / PP 20% GF	1.4301

Accessories



TD 90-2 TUBE DIFFUSER

Dimensions

Material	Tube diameter	ID-Sleeve	Wall thickness
EPDM	87 mm	~ 90 mm	1,90 ± 0,20 mm
Silikon	87 mm	~ 90 mm	1,50 ± 0,20 mm
PUR	87 mm	~ 90 mm	0,6 ± 0,1 mm

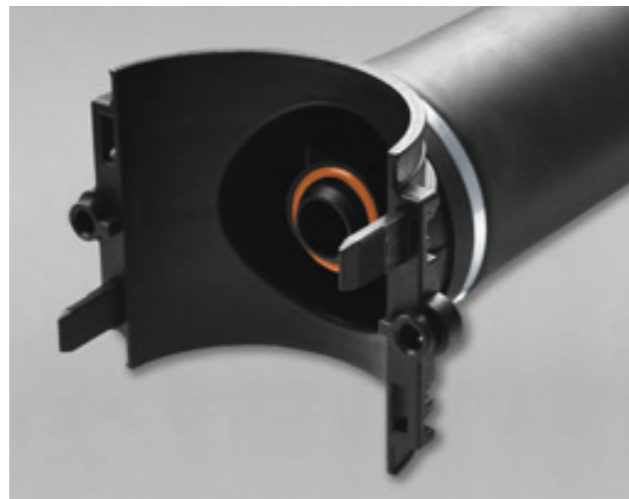

Installation drawing

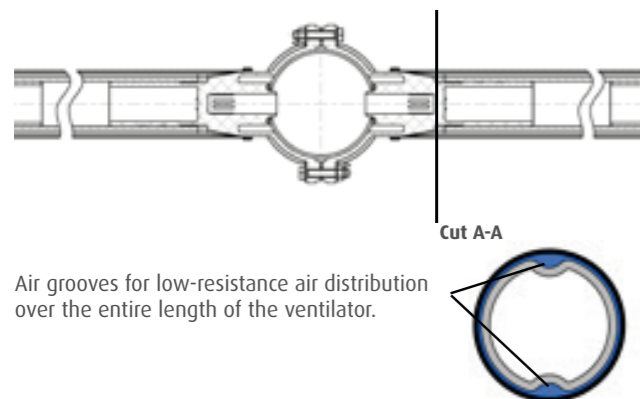

Air grooves for low-resistance air distribution over the entire length of the ventilator.

SSOTE and headloss for EPDM 1000 mm

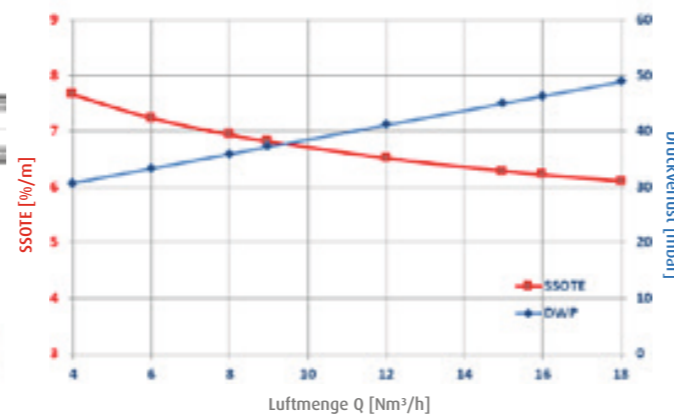

Perforation length	Total length	Perforated area	Air flow rate at standard operating conditions	Max overload/maintenance air flow rate	Operating mode
1000 mm	1195 mm	0,24 m²	4 - 18 Nm³/h	28 Nm³/h	continuous / intermittent
750 mm	945 mm	0,18 m²	3 - 14 Nm³/h	21 Nm³/h	continuous / intermittent
500 mm	695 mm	0,12 m²	2 - 9 Nm³/h	14 Nm³/h	continuous / intermittent

Dimensions for connection to round tubes

Outer diameter	Material	Nominal diameter	Drilling diameter
114,3 mm	SS	100	32 +0,5/-0 mm
110 mm	PVC	100	32 +0,5/-0 mm

TD 90-2 TUBE DIFFUSER

Membrane materials

Material	Norm	EPDMperformance Plus	PUR	Norm	Silikon
Colour		black	green		translucent
Plasticiser (%)		35	0		0
Density (g/cm³)	DIN EN ISO 1183-1	1,11	1,15	DIN EN ISO 1183-1	1,16
Tensile strength (N/mm²)	DIN 53504	>8,5	>35	DIN 53504	>9
Elongation at break (%)	DIN 53504	>550	>500	DIN 53504	>900
Tear strength (N/mm)	DIN EN ISO 34-1	>10	>55	ASTM D 624 B	>38
Hardness (Shore A)	DIN ISO 7619-1	43 ± 5	87 ± 5	DIN 53505	60 ± 5
Operating temperature air (°C)		5 - 80	5 - 80		5 - 100
Operating temperature water (°C)		5 - 40	5 - 40		5 - 40

Other materials

Supporting body	Stainless steel clamp	Screw connection
PP / PP 20% GF	1.4301	1.4301

Accessories

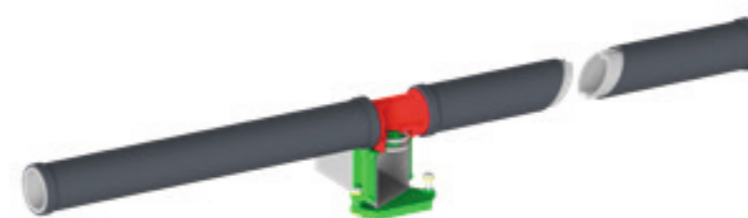

Floor bracket and end plug Half shell without Thread

TD 90-2 G TUBE DIFFUSER

Dimensions

Material	Tube diameter	ID-Sleeve	Wall thickness
EPDM	87 mm	~ 90 mm	1,9 ± 0,20 mm
Silikon	87 mm	~ 90 mm	1,5 ± 0,20 mm
PUR	87 mm	~ 90 mm	0,6 ± 0,1 mm

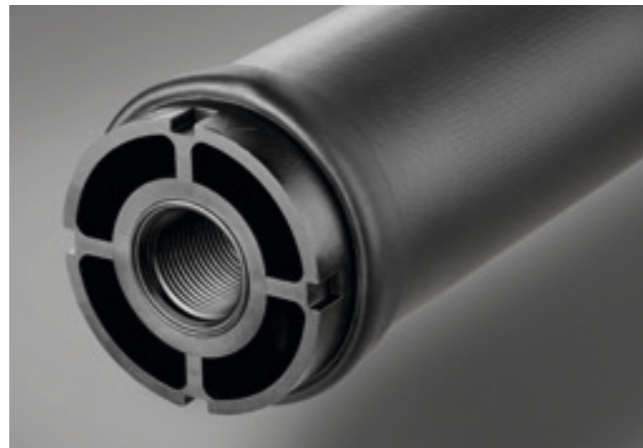

Installation drawing

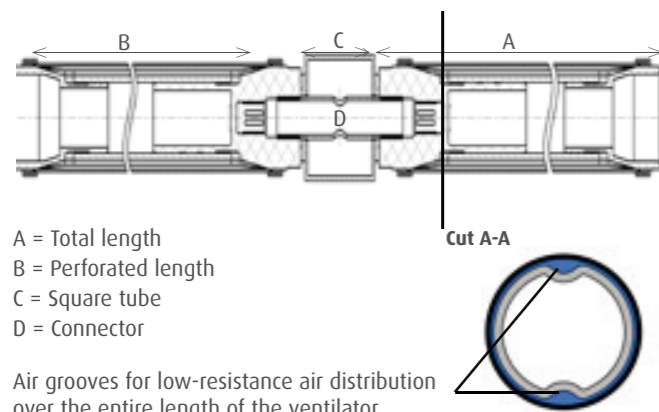

SSOTE and headloss for EPDM 1000 mm

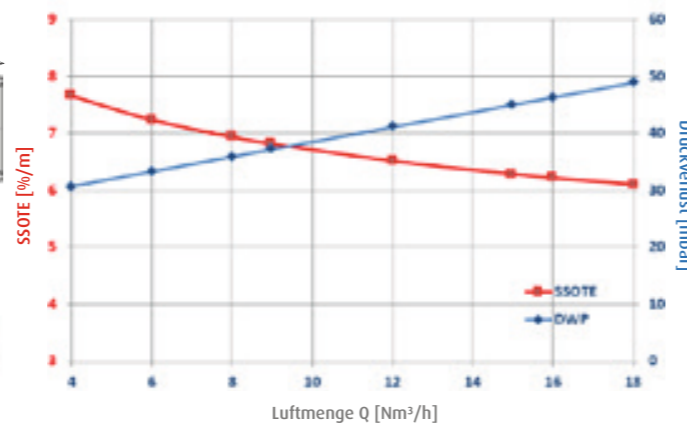

Perforated length [B]	Total length [A]	Perforation area	Air flow rate at standard operating conditions	Max overload/maintenance air flow rate	Operating mode
1000 mm	1145 mm	0,24 m²	4 - 18 Nm³/h	28 Nm³/h	continuous / intermittent
750 mm	895 mm	0,18 m²	3 - 14 Nm³/h	21 Nm³/h	continuous / intermittent
500 mm	645 mm	0,12 m²	2 - 9 Nm³/h	14 Nm³/h	continuous / intermittent

Dimensions for connection to square pipes

Connector	Length for square tube 80 x 80 mm [C]	Length for square tube 100 x 100 mm [C]	Drill hole for connector [D]
Pipe threads ISO 228 -G 1A	145 mm	165 mm	35 +1/-0 mm

TD 90-2 G TUBE DIFFUSER

Membrane materials

Material	Norm	EPDMperformance Plus	PUR	Norm	Silikon
Colour		black	green		translucent
Plasticiser (%)		35	0		0
Density (g/cm³)	DIN EN ISO 1183-1	1,11	1,15	DIN EN ISO 1183-1	1,16
Tensile strength (N/mm²)	DIN 53504	>8,5	>35	DIN 53504	>9
Elongation at break (%)	DIN 53504	>550	>500	DIN 53504	>900
Tear strength (N/mm)	DIN EN ISO 34-1	>10	>55	ASTM D 624 B	>38
Hardness (Shore A)	DIN ISO 7619-1	43 ± 5	87 ± 5	DIN 53505	60 ± 5
Operating temperature air (°C)		5 - 80	5 - 80		5 - 100
Operating temperature water (°C)		5 - 40	5 - 40		5 - 40

Other materials

Supporting body	Stainless steel clamp
PP / PP 20% GF	1.4301

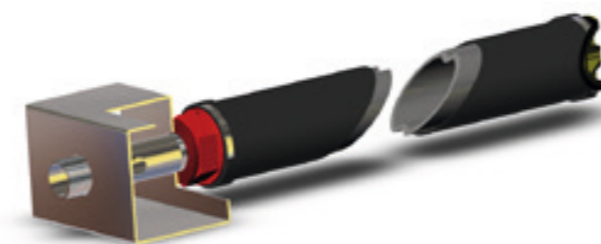

Accessories



TD 63-G

Dimensions

Material	Tube diameter	ID-Sleeve	Wall thickness
EPDMperformance	63 mm	64 - 66 mm	1,9 ± 0,15 mm
EPDM premium	63 mm	64 - 66 mm	1,9 ± 0,15 mm
Silikon translucent	63 mm	64 - 66 mm	1,5 ± 0,15 mm
PUR transparent	63 mm	64,5 mm	0,75 ± 0,025 mm

- Shutdown of operation is highly recommended for air flow rates lower than minimum.
- Do not apply overload air flow rate (e.g. cleaning) for more than 10 minutes each day.
- Numbers are for guidance only. Operating diffusers at too high or too low airflow rate may reduce lifetime or performance. See Technical Report 'Membrane Fouling Issues' for details.



Installation drawing

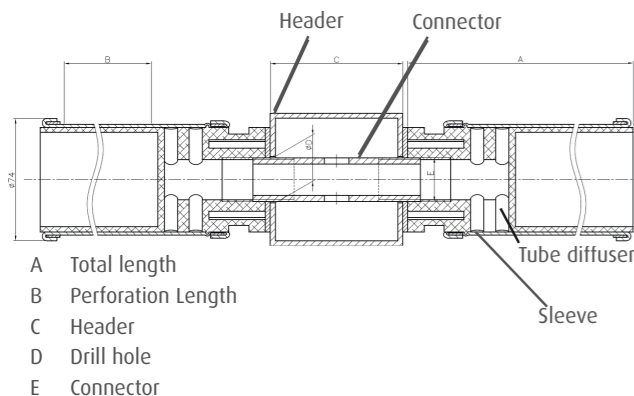

SSOTE and headloss for EPDM 1000 mm

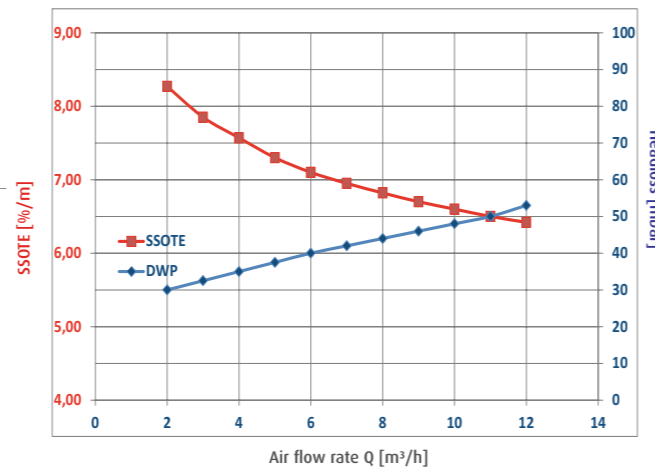

Perforation length [B]	Total length [A]	Perforated area		Air flow rate at standard operating conditions		Max overload/maintenance air flow rate	
		EPDM	SI+PU	EPDM	SI+PU	EPDM	SI+PU
1000 mm	1060 mm	0,18 m ²	0,16 m ²	4 - 12 m _N ³ /h	3 - 8 m _N ³ /h	20 m _N ³ /h	16 m _N ³ /h
750 mm	810 mm	0,135 m ²	0,12 m ²	3 - 9 m _N ³ /h	2 - 6 m _N ³ /h	15 m _N ³ /h	12 m _N ³ /h
500 mm	560 mm	0,09 m ²	0,08 m ²	2 - 6 m _N ³ /h	1 - 4 m _N ³ /h	10 m _N ³ /h	8 m _N ³ /h

Operating temperature air	Operating temperature water	Operating mode	Application
5 - 60 °C	5 - 30 °C	continuous / intermittent	municipal waste water

TD 63-G

Dimensions for threads and connector

Connector [E]	Colour code	Connector length square tube 80 x 80 mm [C]	Connector length square tube 100 x 100 mm [C]	Drill hole for connector [D]
Pipe thread ISO 228 - G 1A	blue	130 mm	150 mm	35 ± 1mm
Pipe thread ISO 228 - G 3/4A	green	130 mm	150 mm	28 ± 1mm
3/4" NPT (only for length 500 mm)	grey	-	-	-

Membrane materials

Material	EPDMperformance	EPDMpremium	Silicone	PUR	
Colour	black	black	translucent	transparent	
Polymer	33 %	38 %	50 %	100 %	
Carbon black	20 %	22 %	0 %	0 %	
Plasticiser	35 %	21 %	0 %	0 %	
Others	12 %	19 %	50 %	0 %	
Density	DIN EN ISO 1183-1	1,11 ± 0,03 g/m ³	1,17 ± 0,03 g/m ³	1,16 ± 0,03 g/m ³	1,18 ± 0,03 g/m ³
Tensile strength	DIN 53504	> 7 MPa	> 7 MPa	> 9 MPa	40 MPa
Elongation at break	DIN 53504	> 400%	> 400%	> 600%	≥ 600 %
Tear strength	DIN EN ISO 34-1	> 7,5 N/mm	> 4,5 N/mm	> 20 N/mm	65 N/mm
Hardness	DIN ISO 7619-1	40 ± 5 Shore A	47 ± 5 Shore A	60 ± 5 Shore A	
Tension set	DIN ISO 2285, 100% Elongation; 24 h, RT	< 7%	< 7%		
Ozone resistance	DIN ISO 1431-1 (500ppb)	no cracks	no cracks	no cracks	no cracks

Other materials

Pipe	Head	Clamp	Gasket	Connector
PP	PP 30% GF	1.4301	EPDM/SI	1.4301

Accessories

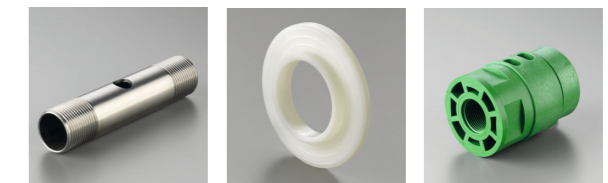

Stainless steel connectors (square headers) Adapters Blind plugs



Plastic connectors/saddles (round headers) Sealing for adapters Clamp adapter (round headers)

ACCESSORIES FOR DISC DIFFUSERS

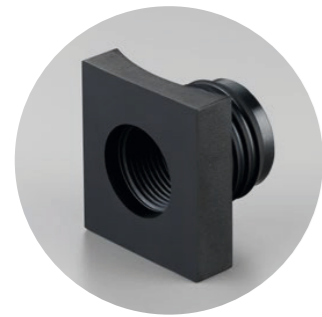

Rubber Saddles

JetFlex® Disc Diffusers with R $\frac{3}{4}$ " nipple may be installed onto all plastic pipes suitable for waste water and hot air. Grommets are suitable for all plastic pipes with outer diameter between 63 and 80 mm respectively 88 and 141 mm (3 $\frac{1}{2}$ and 5 $\frac{9}{16}$ inch). Wall thickness for the Universal Saddle should be between 4 and 8 mm (5/32 and 5/16 inch). The exertion force for this saddle is approximately 850 N with discs properly installed. Universal Saddles work with all JetFlex® disc diffuser with $\frac{3}{4}$ " male thread. For further details please refer to our Technical Information "Installation (of JetFlex® Disc Diffusers) using EPDM-Grommets".

Description	Material	Color
rubber saddle universal R35	EPDM	black
rubber saddle universal R55	EPDM	black



PVC Saddles

PVC Saddles are made from U-PVC and may be glued onto 90 and 110 mm PVC pipes (U-PVC and/or C-PVC). They are equipped with a G $\frac{3}{4}$ " female thread. The opening in the header pipe should measure 36 ± 0.5 mm. You may rectify slight deviations in diameter and position of bore by accurately positioning the saddle on top of the pipe, thread pointing exactly upwards. For detailed information on gluing the saddle to the header please refer to instructions from glue manufacturers, e.g. Tangit by Henkel at www.tangit.com or equivalent. You may have to secure the position of the clamp by cable ties or similar means for 5 minutes or more depending on temperature.

Description	Material	Color
saddle 90 mm	PVC	white
saddle 90 mm	soft PVC	transparent
saddle 110 mm	PVC	white
saddle 110 mm	soft PVC	transparent



Check Valve

(for JetFlex® HD200, HD270 and HD340 with R $\frac{3}{4}$ external thread)

Check valves (non-return-valves) consist of a PP housing containing an 8 mm SS-ball. The stainless-steel ball prevents backflow of sludge into headers in case of damage to the membrane of the disc. Check valves alter the headloss characteristic of JetFlex® disc diffusers, so do not install discs with and without check valve in the same tank or on the same grid. Check valves work best if discs are installed using our clamp adapters 90 N or our rubber saddles, see above.

Description	Material	Color
non-return valve	PPC30%GF/SS	white

ACCESSORIES FOR DISC & TUBE DIFFUSERS

Clamp Adapters

Clamp adapters come in a variety of sizes and threads. They require a 40 +0 -1 mm resp. 16 +1 -0 mm hole in the header pipe. For disc diffusers this hole must point exactly upwards. Short tube diffusers (max. 560 mm length) have to be leveled within ± 5 mm at the ends, so both 40 mm holes must be aligned horizontally. Tube diffusers longer than 560 mm should be fixed using our fixing plates and L-brackets mentioned on page 6. All clamps come with a cable-tie-like mounting aid freeing your hands during installation. Clamps are installed in pairs. You need two threaded ones (1" male) for a pair of tubes or one threaded and one blind one for a single tube. Discs require one threaded and one blind clamp.

Clamp adapters 90N have been designed especially for 90 mm headers with existing openings of about 15 mm. You may connect any JetFlex® disc diffuser with a set of one 90N-clamp R $\frac{3}{4}$ and one blind clamp. This threaded clamp easily accommodates our check-valve giving you full compatibility, if necessary. Clamp adapter 90N-G1 male thread may be used to connect tube diffusers onto 90 mm plastic headers. The clamp requires a 16 mm opening in the header (+1/-0 mm). This clamp causes some additional headloss for airflow rates above 8 m³/h per diffuser. Nuts, bolts and washers are within the scope of supply. O-Ring/sealing is included with all threaded clamps.



Clamp Adapters with external thread (only for TD65-2)

Description	Material	Color
clamp adapter 114.3 with 1" external thread	PP20%GF/SI/VA	black
clamp adapter 110 mm with 1" external thread	PP20%GF/SI/VA	black
clamp adapter 90 N-G1 with 1" external thread	PP20%GF/SI/VA	black



Clamp Adapters with internal thread

Description	Material	Color
clamp adapter 114,3 mm with $\frac{3}{4}$ " internal thread	PP20%GF/SI/VA	black
clamp adapter 110 mm with $\frac{3}{4}$ " internal thread	PP20%GF/SI/VA	black
clamp adapter 90 mm with $\frac{3}{4}$ " internal thread	PP20%GF/SI/VA	black



Clamp Adapters without thread (114.3 and 90 only for TD65-2)

Description	Material	Color
clamp adapter 114,3 mm without thread	PP20%GF/VA	black
clamp adapter 110 mm without thread	PP20%GF/VA	black
clamp adapter 90 mm without thread	PP20%GF/VA	black

ACCESSORIES FOR TUBE DIFFUSERS



Adapter

Existing diffusers on square tubes may be mounted using different connectors and openings. We carry adapters for existing openings of 40 and 45 mm. There is no need for an additional sealing.¹ The existing connectors are replaced by our 1" stainless-steel connectors, see further below.

Description	Material	Color
Flange sealing 40 mm	Desmopan	white
Flange sealing 45 mm	Desmopan	white

¹ As a matter of principle each carton with tube diffusers contains the appropriate amount of EPDM or silicone sealings. In combination with Desmopan Adapters you must not install the standard seals.



Stainless-steel clamps

Replacing sleeves requires new clamps to secure sleeves on support tubes. We do not recommend the use of worm-gear-clamps as these clamps may squeeze and crimp the sleeve. This may damage the sleeve or cause air-leakage at the clamp. See our installation instructions for details. V2A clamps (SS304) are stocked, V4A clamps (SS316) are available, too, but non-stock items.

Description	Material
clamp 66.5	V2A
clamp 68.0	V2A
clamp 69.5	V2A
clamp 95.0	V2A



Pincer

This pincer is ideally suited to close above mentioned stainless-steel clamps. A regular pair of pliers may deform the ear of the clamp and is regarded as an emergency repair tool only.

ACCESSORIES FOR TUBE DIFFUSERS



Sealing for Tube Diffusers JetFlex® TD65-2 G

Tube diffusers usually include all necessary sealing. If for any reason diffusers are disassembled we strongly recommend replacing the seals upon re-installation.

Description	Material	Color
sealing TD65-2 G1	silicone	red
sealing TD65-2 G¾	silicone	red



Sealing for Tube Diffusers JetFlex® TD63-0 (formerly TD 63/2 - - -)

Tube diffusers usually include all necessary sealing. If for any reason diffusers are disassembled we strongly recommend replacing the seals upon re-installation.

Description	Material	Color
sealing 63x27x4 mm	EPDM	black
sealing 63x34x4 mm	EPDM	black
sealing 63x27x4 mm	silicone	red
sealing 63x34x4 mm	silicone	red



Blind Plugs

Many tube diffusers in Europe are installed onto square-tube-headers. Occasionally there is the need to omit individual diffusers due to obstructions in the tank etc. Blind plugs allow you to install a single diffuser either side of the header. Of course, a pair of diffusers may be replaced by a pair of blind plugs, too. Diffusers with ¾" NPT usually are not installed in pairs, so the applicable blind plug serves as a cap or plug to shut off unused existing connections.

Description	Material	Color
blind plug ¾"	PP30%GF	green
blind plug 1"	PP30%GF	blue
blind plug ¾" NPT	PP30%GF	grey

ACCESSORIES FOR TUBE DIFFUSERS



Fixing Plates

Tube diffusers may be exposed to high water currents near blade mixers etc. This may cause oscillatory instability particularly with regard to long diffusers. In order to avoid flapping of diffusers this special end cap may be inserted into the far end of the tube and fixed to the ground. The end cap does not hamper water flowing into the open end of the diffuser keeping the buoyancy of the tube low. Please specify installation height of diffusers in order to select the proper length of the SS brackets.

Description	Material	Color	Threaded nut
Fixing plate for TD63	PP	green	M10
Fixing plate for TD65	PP	black	M8



Tail support

Description	Material
Bolt, washer, L-bracket	SS



Pipe Support

Pipe supports are made from stainless steel (ANSI 304/316) with adjustable height for laterals and headers in order to achieve optimum uniformity of aeration. Available sizes are for 3,5" and 7" laterals and headers as well as for 50, 110, 140, 160, 200 mm metric sizes. Please, call for details.

Description	Material
Pipe support	SS

ACCESSORIES FOR TUBE DIFFUSERS

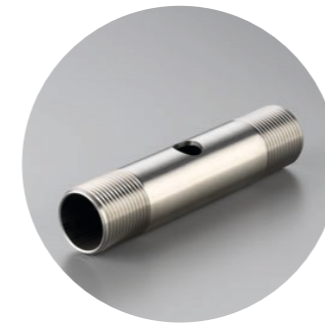

Stainless-Steel Connectors (Square headers)

For almost all kinds of square and rectangular pipes there is a connector for our tube diffusers. Other lengths are available on request.

Description	Material
3/4" connector, length 130 mm	V2A
3/4" connector, length 150 mm	V2A
1" connector, length 130 mm	V2A
1" connector, length 150 mm	V2A
1" connector, length 170 mm	V2A
3/4" connector, length 145 mm	V2A
3/4" connector, length 165 mm	V2A
1" connector, length 145 mm	V2A
1" connector, length 165 mm	V2A
1" connector, length 185 mm	V2A



BIBUS GmbH

Max-Eyth-Straße 41/1
DE-89231 Neu-Ulm

Phone: +49 731 20769-0
Telefax: +49 731 20769-620

E-Mail: info@bibus.de
www.bibus.de

